

Copyright and ownership of this drawing is vested in Brinkmann & Niemeijer Motoren B.V., whose prior written consent is required for its use, reproduction or for publication to any third party. All other rights reserved.

Changings reserved

# 66 kVA

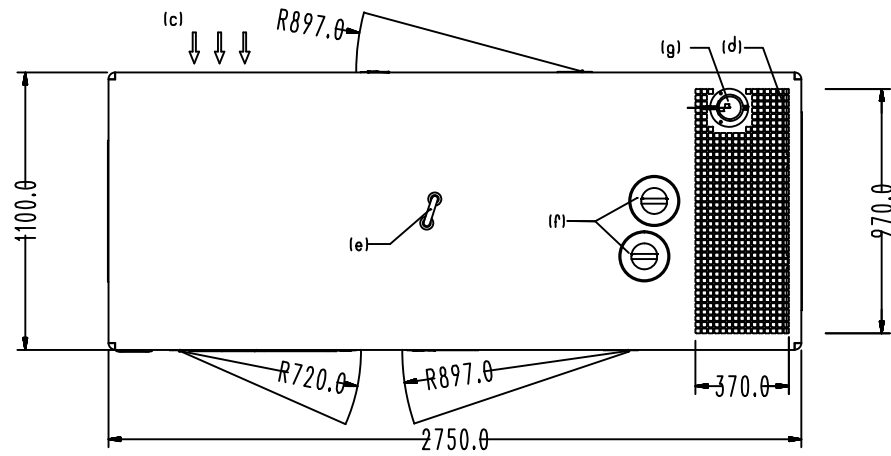

- (a) Access to drain
- (b) Mounting on floor (4x ø16 mm)
- (c) Air inlet
- (d) Air outlet
- (e) Lifting point
- (f) Radiator access
- (g) Exhaust outlet ø90 mm
- (h) Power sockets
- (i) Cable gland
- (j) External fuel supply
- (k) External fuel supply connections 3 way manifold (optional)
- (l) Access to drain
- (m) Oil drain

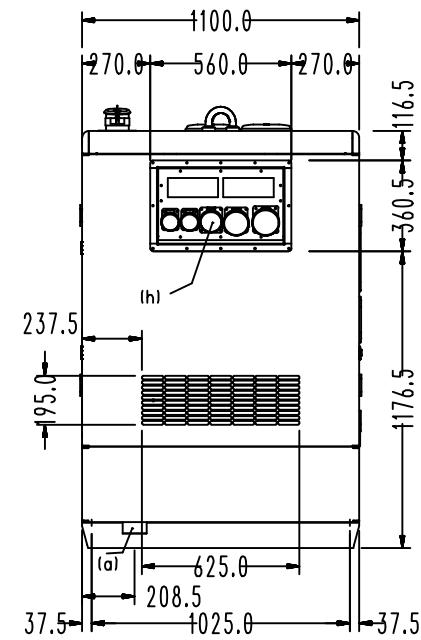
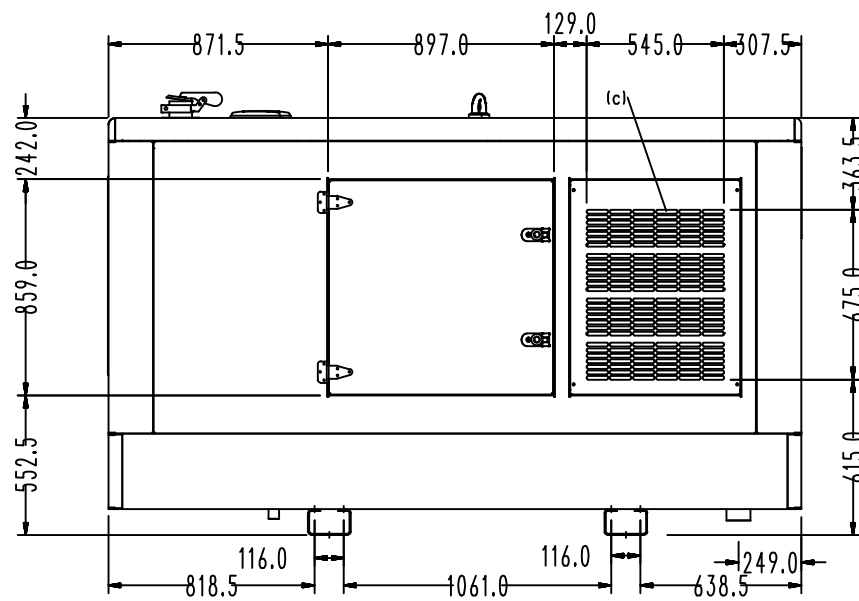
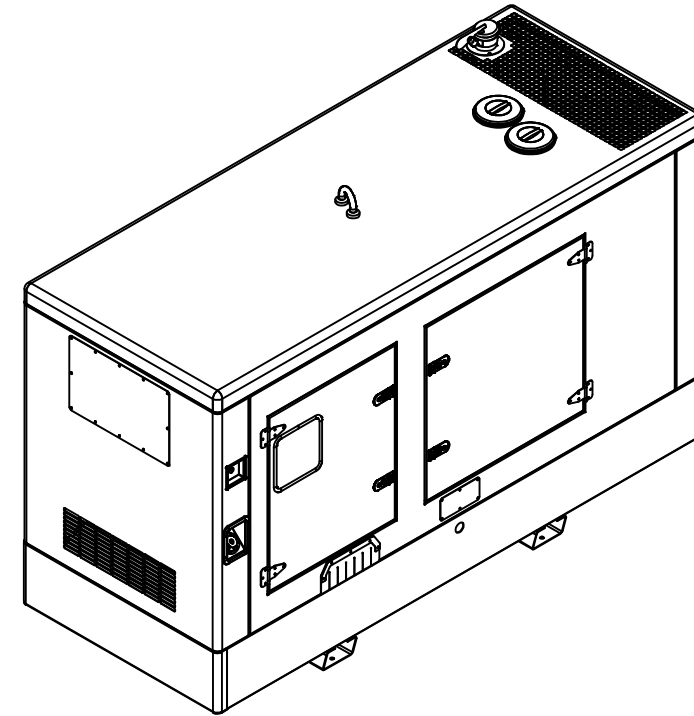
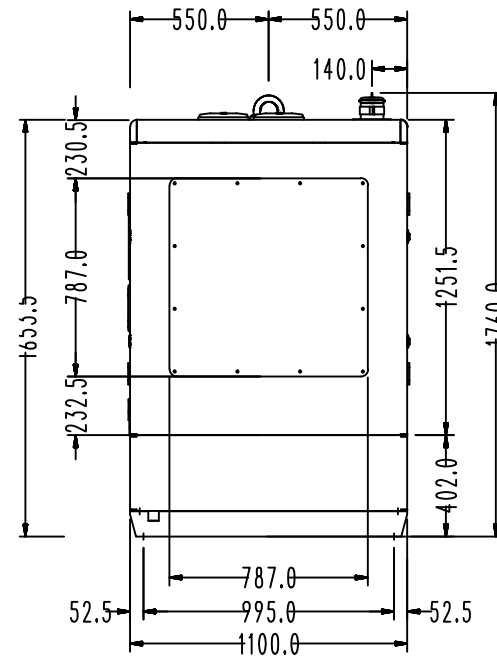
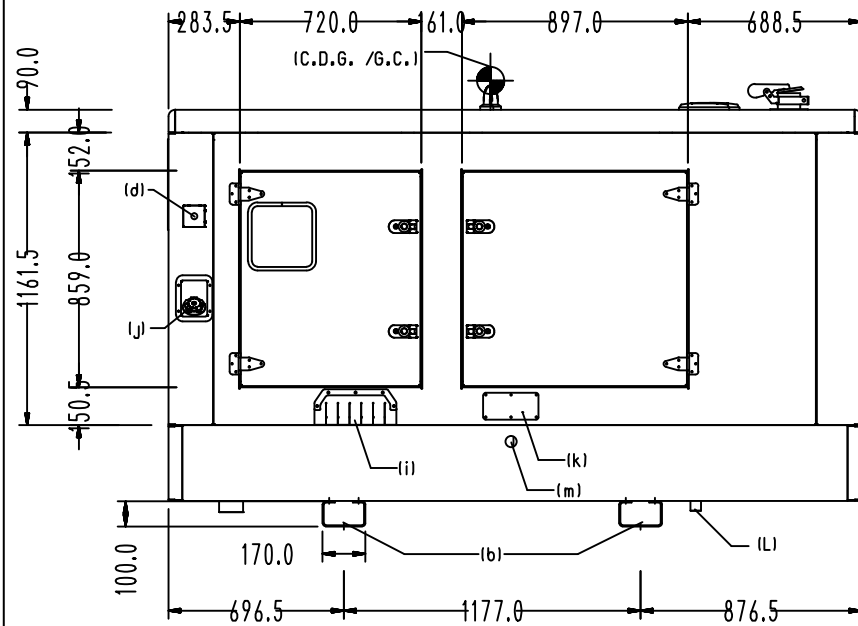

JCB 444 G-TC1

Deze tekening blijft eigendom van Brinkmann & Niemeijer Motoren B.V. en mag zonder haar schriftelijke toestemming niet gecopieerd worden of aan derden ter inzage worden gegeven. Alle overige rechten voorbehouden.

Wijzigingen voorbehouden

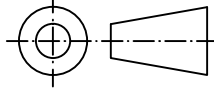
RUWHEID VOLGENS NEN 3634	ISO-PASSINGSTELSEL NEN-ISO 286-1 EN-2	VORM- EN PLAATSTOLERANTIES VOLGENS NEN-ISO 1101	
AMERIKAANSE PROJECTIE	SCHAAL: 1:30	GETEKEND: DJ	OPMERKINGEN:
	MAATEENHEID: MM	AFDELING: Engineering	
	DATUM: 24-09-2012	GEZIEN:	
BRINKMANN & NIEMEIJER MOTOREN BV		BENAMING: G66QX	TEK.NR.: C151053 <sup>A</sup>
			FORMAAT: A3