

Copyright and ownership of this drawing is vested in Brinkmann & Niemeijer Motoren B.V., whose prior written consent is required for its use, reproduction or for publication to any third party. All other rights reserved.

Changings reserved

20 kVA

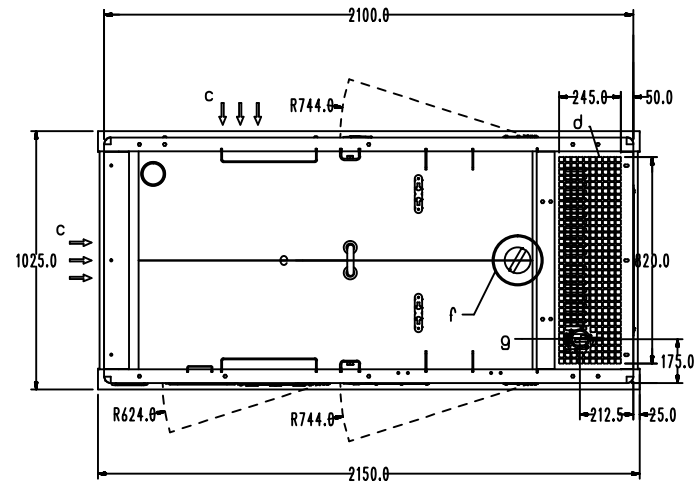

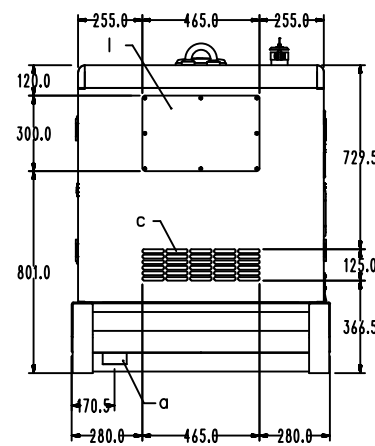
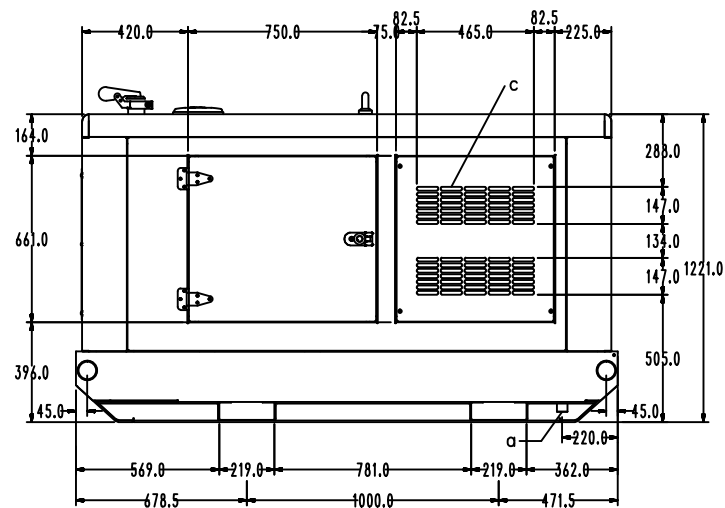
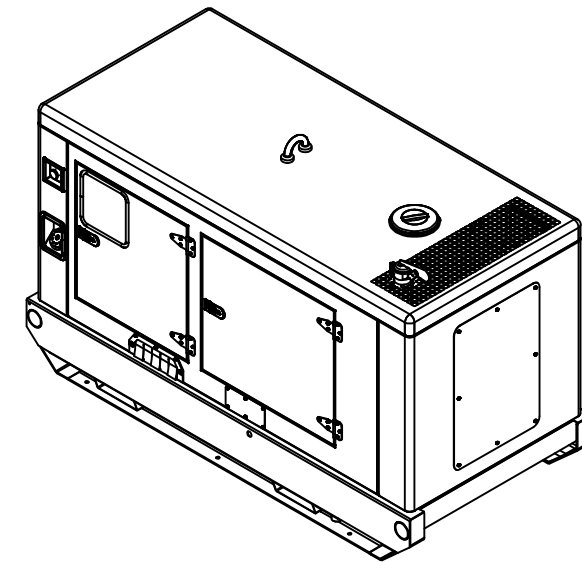
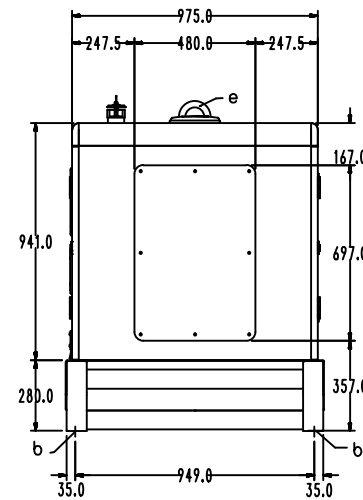
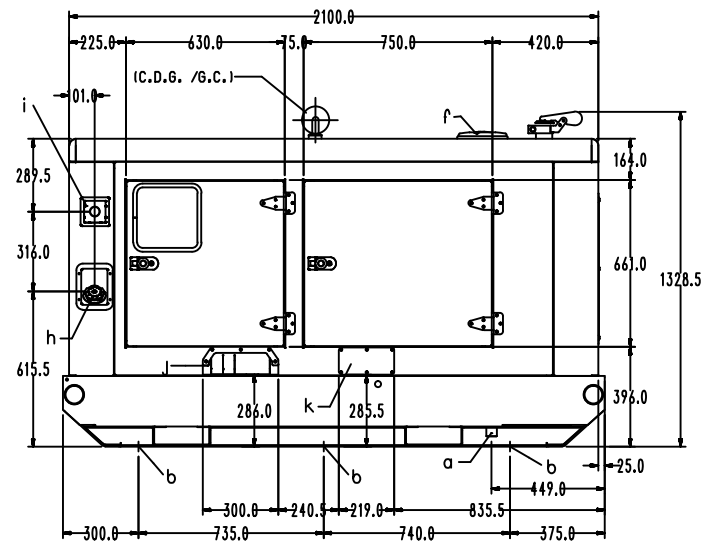

- (a) Access to drain
- (b) Mounting on floor (4x ø16 mm)
- (c) Air inlet
- (d) Air outlet
- (e) Lifting point
- (f) Radiator access
- (g) Exhaust outlet ø65 mm
- (h) External fuel supply
- (i) Emergency stop
- (j) Cable gland
- (k) External fuel supply connections 3 way manifold (optional)
- (l) Receptacle box (optional)



Deze tekening blijft eigendom van Brinkmann & Niemeijer Motoren B.V. en mag zonder haar schriftelijke toestemming niet gecopieerd worden of aan derden ter inzage worden gegeven. Alle overige rechten voorbehouden.

Wijzigingen voorbehouden

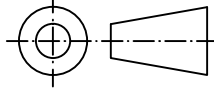
Yanmar 4TNV84T

RUWHEID VOLGENS NEN 3634	ISO-PASSINGSTELSEL NEN-ISO 286-1 EN-2	VORM- EN PLAATSTOLERANTIES VOLGENS NEN-ISO 1101		
AMERIKAANSE PROJECTIE 	SCHAAL: 1:30	GETEKEND: DJ	OPMERKINGEN:	
	MAATEENHEID: MM	AFDELING: Engineering		
DATUM: 25-09-2012	GEZIEN:			
BRINKMANN & NIEMEIJER MOTOREN BV 		BENAMING: G21RX	TEK.NR.: C151086 ^A	FORMAAT: A3