

G2200X | Open Set

PRIME KVA: 2080.00 | STANDBY KVA: 2250.00

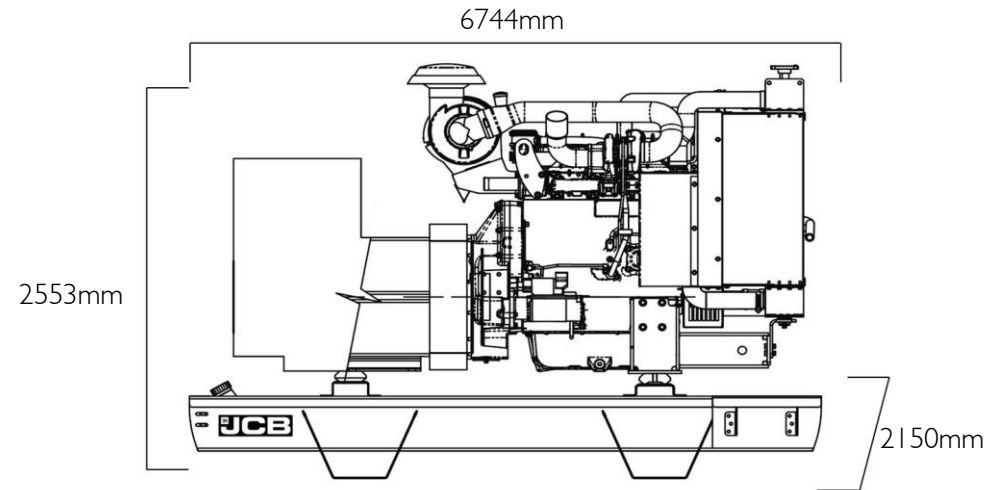

DIESEL GENERATOR

FUEL OPTIMISED

ELECTRICAL

Frequency (Hz)	Phases	Voltage (V)	Prime		Standby		MCB Rating (A)	Minimum ATP Rating (A)	Rated Speed (RPM)
			kVA	kW	kVA	kW			
50	3	400/230	2080.00	1664.00	2250.00	1800.00	3200.00	3200.00	1500.00

POWER FACTOR

3 Phase	0.8
1 Phase	1

MAXIMUM LOAD IMPACT*

kVA	-
kW	-

*With 20% voltage and 10% frequency deviation @ 50Hz, 400V

ALL RATINGS ARE TO STANDARD REFERENCE CONDITIONS ISO 8528

Prime: This rating is for the supply of continuous electrical power, at variable load, in lieu of commercially purchase power. There is no limitation on the annual hours of operation and 10% over load power can be supplied for 1 hour in 12.

Standby: This rating is for the supply of continuous electrical power, at variable load, in the event of a utility power failure. No overload is permitted.

"Stage IIIa" models are only emissions compliant at 50Hz Prime Power in accordance with 97-68EC.

G2200X | Open Set

PRIME KVA: 2080.00 | STANDBY KVA: 2250.00



CANOPY/SKID

Lockable Maintenance Access Doors	x
Control Panel Viewing Window	x
Fork Pockets	x
Single Lift Point	x
Rental Sledging Base	x
Bunding	Δ
Open Frame	●
Bund Level Indicator	Δ
50mm Rock Wool Sound Insulation	x
Yellow Paint	x
Red Paint	x
White Paint	x

Standard: ● Not Available: x Optional: Δ

ALTERNATOR

Poles	4
Winding Connections	Star
Insulation	Class H
Enclosure	IP23
Exciter System	Self-regulating brushless
Voltage Regulator	AVR
Steady State Voltage Regulation	+/- 1.0%
Bearing	Single bearing sealed
Coupling	Flexible disc
Cooling	Direct drive centrifugal blower fan
Coating	Winding Protection Grey

STARTING SYSTEM

Starter Motor	kW	9 (2 of)
Battery Capacity	Ah	300
Number of Batteries		4
Auxiliary Voltage	V	24

ENGINE

1500 RPM		
Output Rating (PRP)	kW	1738.00
Output Rating (Standby)	kW	1918.00
Manufacturer and Model		MTU 16V4000G23
Fuel		Diesel
Injection		Direct
Aspiration		Turbo Charged with Aftercooler
Cylinders		V16
Bore and Stroke	mm	170 x 210
Displacement	L	76.30
Cooling		Coolant
Engine Oil Specification		S10 W40
Compression Ratio		16.5:1
Engine Oil Capacity	L	300.00
Coolant Capacity	L	605.00
Governor		Electronic
Air Filter		Heavy Duty
Engine Oil Consumption	100% Load	1 % of fuel consumption

FUEL SYSTEM

Diesel Specification		BS2869 Class A or ASTM D975 No.2
Standard Fuel Tank Capacity	L	400

FUEL TANK OPTIONS

	Material	Capacity (L)
Standard Tank	Steel	400
Tank Option 1	x	x
Tank Option 2	x	x

G2200X | Open Set

PRIME KVA: 2080.00 | STANDBY KVA: 2250.00



FUEL CONSUMPTION

100% Load Prime	L/h	50Hz	401.41
75% Load Prime	L/h		305.76
50% Load Prime	L/h		214.30
100% Load Standby	L/h		439.30

EXHAUST SYSTEM

Maximum Temperature 100% Standby	°C	50Hz	485.00
Exhaust Gas Flow 100% Standby	m ³ /min		348.00
Maximum Allowed Back Pressure	mbar		85.00
Exhaust Flange Size	mm	Internal Diameter 251.00	

AIR SYSTEM

Intake Air Flow 100% Standby	m ³ /h	50Hz	8280.00
Total Cooling Air Flow 100% Standby	m ³ /s		38.89
Alternator Fan Airflow	m ³ /s		2.69

SOUND PRESSURE (CANOPY ONLY)

LpA (7m)	50Hz	dB(A)	-
----------	------	-------	---

MECHANICAL FEATURES

Cooling Pack	●
Air Filter	Dry
Mechanical Governor	x
Electronic Governor	●
High Coolant Temperature Sender	●
Low Oil Pressure Sender	●
Advanced Coolant Temperature Sender	●
Advanced Oil Pressure Sender	●
Oil Temperature Sender	Δ
Water Level Sender	●
Radiator Guards	●
Hot Component Guards	●
Manual Oil Drain Pump (Canopy)	●
Water Jacket Heater	●
Manual Fuel Fill	Δ
Electric Fuel Fill	Δ
Racor Fuel Filter (No Alarm)	●
Racor Fuel Filter (With Alarm)	Δ
Pre-Filter with Separator	●
External Spark Arrestor	Δ
Fuel Level Sender	●
Fuel Heater	Δ
External Fuel Fill (Belly Tank)	x
3 Way Fuel Valve and Coupling Nest	●
Residential Silencer	Δ
Industrial Silencer	●

Standard: ● Not Available: x Optional: Δ

G2200X | Open Set

PRIME KVA: 2080.00 | STANDBY KVA: 2250.00



ELECTRICAL FEATURES

AVR DSR	x
AVR DER	●
Winding Protection Standard	x
Winding Protection Standard +	x
Winding Protection Grey	●
Winding Protection Total	Δ
Winding Protection Total +	Δ
MAUX	●
PMG	Δ
Anti-Condensation Heater	Δ
Air Circuit Breaker	●
Moulded Case Circuit Breaker (with integrated busbar)	x
Earth Leakage Protection (Shunt Trip)	●
Synchronisation	Δ
Socket Box (inclusive of heavy duty busbar & micro switch)	x
Preparation for Earth Spike	●
Optional Voltages	Δ
Remote Screen	Δ
Panel Door Micro Switch	Δ
Copper Busbar/Tails	●
Emergency Stop Button	●
External Emergency Stop Button	x
Standard: ● Not Available: x Optional: Δ	

BATTERY FEATURES

Battery Isolator	●
Battery Type	Gel
Battery Size (Ah)	75
Number of Batteries	4
Optional Battery	x
Battery Charger	●
Standard: ● Not Available: x Optional: Δ	

JCB COMMUNICATION AND CONTROL

KS1	x
CPI	●
CP2	Δ
ATP	Δ
CAN/USB	Δ
CAN/LAN	Δ
CAN RS-232	Δ
Remote Modem	Δ
Standard: ● Not Available: x Optional: Δ	

SYNCHRONISATION PANEL (OPTION)

DSE8610	Δ
DSE8620	Δ
Standard: ● Not Available: x Optional: Δ	

WEIGHT AND DIMENSIONS

Length	mm	6744
Width	mm	2150
Height	mm	2553
Shipping Volume (sea ready)	m ³	37.02
Weight*	Kg	17469.00

*Standard build with all fluids except fuel

REFERENCE STANDARDS

JCB Generators are CE certified and conform to the following Directives (subject to a country requiring such standard):

- EN 12100, EN13857, EN60204
- 2006/42/CE Machinery safety
- 2006/95/EC Low voltage
- 2004/108/CE Electromagnetic compatibility
- 2000/14/EC Sound Power Level (amended by 2005/88/EC)
- 97/68/EC Emissions(amended by 2002/88/EC & 2004/26/EC)
- Power according to ISO 8528 and ISO 3046
- Ambient reference conditions 1000mbar, 25°C, 30% relative humidity ISO3046

Information based on standard specification equipment unless otherwise stated.